

LOWERING THE PATIENT

- Position the patient over the chair or bed to be lowered into and begin lowering. Check to make sure patient remains comfortable during descent.
- All General Purpose slings have handles sewn onto the the back of the sling. These will assist the carer to pull the patient back into the correct position for seating.

REMOVING THE SLING

Removal of the General Purpose Sling is the reverse of fitting.

- If the patient is in a chair ease leg sections from under each thigh and slide sling up from the back of the patient.
- If the patient has been lowered onto a bed, it may be necessary to roll them but usually the sling can be simply slid out from under the patient.

SLING MAINTENANCE AND CARE

WARNING: Prior to use, inspect slings including webbing, straps and buckles for wear. Examine stitching for fraying, breakage and unravelling. Damaged slings should not be used. If in doubt, do not use.

- **General External Wear.** In normal use, this is unavoidable and is shown by a fluffiness of the surface fibres of fabrics.
- **Local Abrasion.** This may be caused by the passage of webbing over sharp edges or protrusions whilst under tension.
- **Cuts, Holes or Burns in the Webbing.** These are potentially dangerous and must lead to instant rejection of the product.
- **Chemical Attack.** If contamination is suspected, wash out well in warm water. Avoid contact with excessive heat which is likely to affect the product.
- **Examination of Fittings.** Carefully examine buckles for ease of adjustment and absence of sharp edges or burrs likely to abrade the webbing.
- **Examination of Stitching.** Examine stitch patterns for broken, worn, pulled or unravelled stitches. Reject any product where the thread has become subject to excessive abrasion or broken stitches.
- **Cleaning.** For normal washing and cleaning, follow the care instructions on the label of the product.
- **Storage.** Slings should be stored away from direct sunlight where they are not subjected to unnecessary strain, stress or pressure or to excessive heat or humidity.

- **Washing Instructions.** Mild soap solution only, temperature to 85°C max, followed by a rinse. Do not use bleach, cleaning solvents or harsh detergents. Do not iron. Do not dry clean. Do not tumble dry. Avoid UV light and heat. Do not dry in sunshine. Do not place on heaters or steam pipes. Do not autoclave. Dry in warm room only.

NOTE; all Velcro fastening torso belts must be laundered and stored with the belt fully fastened. This will help eliminate any Velcro abrasion damage.

IF IN DOUBT ABOUT THE CONDITION OF A SLING, DO NOT USE IT.

SLING RANGE

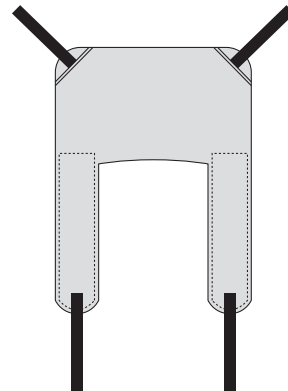

GENERAL PURPOSE SLING

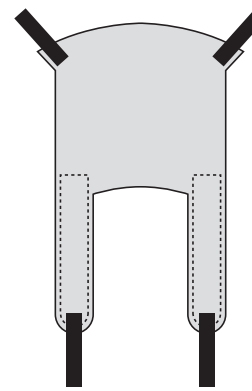

GENERAL PURPOSE HEAD SUPPORT SLING

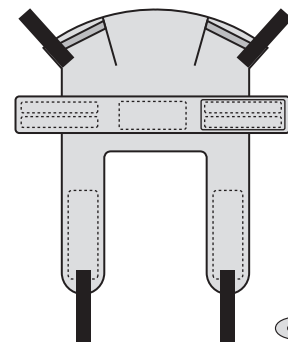

CARE HEAD SUPPORT SLING

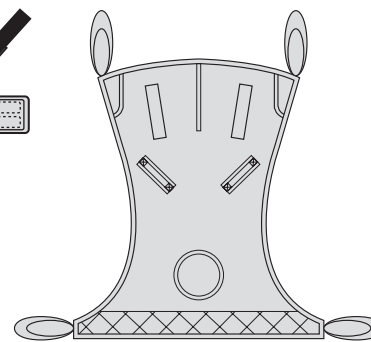

AMPUTEE SLING



Active Mobility

GENERAL PURPOSE SLINGS

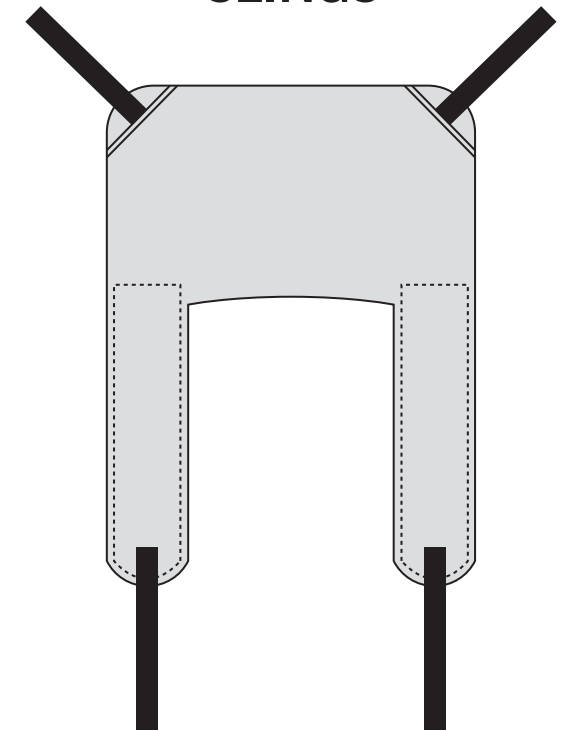

INSTRUCTIONS FOR USE

ACTIVE MOBILITY SYSTEMS PTY LTD

UNIT 8, 110-120 SILVERWATER ROAD

SILVERWATER NSW 2128

PH: 02 9649 2111

EMAIL: sales@activemobility.com.au

WEB: www.activemobility.com.au

FITTING THE SLING

WARNING

Prior to use inspect slings including webbing straps for wear. Examine stitching for fraying, breakage and unravelling. Damaged slings should not be used. If in doubt, do not use.

Always fit the sling to the patient before moving the patient lifter into position to carry out the desired lift.

Sling Fitting Procedure from Chair

- Hold the sling by the U-shaped base section, with the label sewn onto the sling facing away from the patient.
- Slide the sling down the patient's back until the apex of the U section is positioned level with the base of the patient's spine.
- Grasp each leg section of the sling and pass it under each thigh. It is important to ensure that the maximum amount of the leg section supports as much of the patient's hip and thigh as possible. To assist in achieving this, pull firmly on each leg section once it is passed under the leg.
- Bring the leg straps up through the inside of the patient's legs.

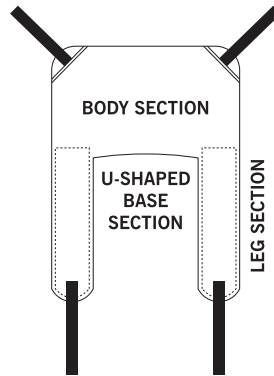

Sling Fitting Procedure for Bed or Floor Lift

- The sling should be positioned under the patient's back. To achieve this the patient may be sat up, or if not possible, the patient must be rolled onto the sling using the same technique as for a draw sheet.



- Roll the patient towards you and ease half the sling underneath. Roll opposite direction and ease from underneath the second half of the sling.
- Bend the Patient's knees slightly one at a time and pass the leg straps under each thigh.

LIFTING PROCEDURES

Tips

- Carer should be fully conversant and trained in the use of the lifter and sling. This will decrease patient apprehension and increase their co-operation and safety of the lifting process.
- Where possible always pull the lifter for maximum safety and comfort.
- Move the hoist slowly to avoid patient swing.
- The hoist should not be used on ramps greater than 5 deg.
- Never leave a patient in a sling unattended.
- Ensure brakes of the chair, bed, trolley that the patient is being lifted from are locked.
- The brakes of the lifter must be **OFF**. This allows the lifter to create its own centre of gravity (C.G.) over the weight of the patient. N.B. This action may result in the lifter moving slightly during the initial phase of the lift.

Lifting Procedure from Bed

- Manoeuvre the hoist under the bed. Lower the spreader bar sufficiently to secure the sling loops to the spreader bar hooks.
- Lift the patient slightly off the bed to ensure correct positioning and comfort. Once satisfied ensure sling attachment loops are still correctly positioned on the spreader bar and begin the lift again. When patient is lifted to sufficiently clear the bed gently pull the lifter away from the bed.

Lifting Procedure from Chair

- Before raising the patient ensure that the sling loop attachments are still correctly held on spreader bar hooks.
- Slightly lift patient to check correct sling positioning and patient comfort.
- Once satisfied begin lift again and lift to allow sufficient clearance of chair.
- Gently pull hoist away. Once the patient is clear of the chair they may be rotated to the correct position to complete the transfer.
- Reposition lifter if required and lower to appropriate device.

Lifting Procedure from Floor

- Position sling under patient's back as per instructions.
- Spread base of lifter and bend patient's knees so one leg of lifter can pass under bent knees.
- If patient is suspected to have fragile skin protect with pillow or towel.

WAYS TO FIT A GENERAL PURPOSE SLING

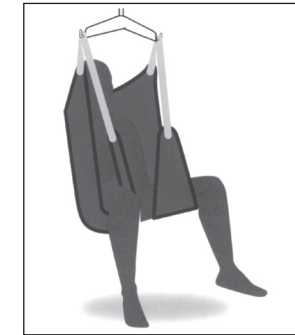

Leg straps passing under each thigh and returning to the same loop on the same side. This provides a legs apart posture which is suitable for hygiene and personal washing.

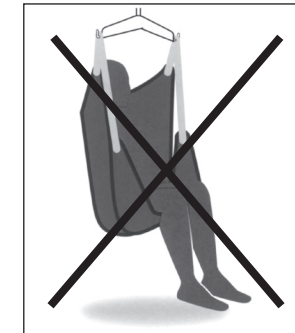

DANGEROUS!
This method should never be used.



Leg straps passing under each thigh and onto the opposite hooks. This is the safest method. The patient is well supported and prevented from slipping and tipping forward by the crossing straps.

MOVING THE PATIENT

A PATIENT HOIST IS PRIMARILY A LIFTING DEVICE. If possible always move patients from room to room in a wheelchair or other transport device. However, if you must move a patient while supported in a lifter the following are suggested:

- Lower the patient so the feet are just off the ground. This enhances the patient's perception of security.
- Where possible, always pull the lifter rather than push, in particular when changing direction or steering around corners, walk the back of the hoist around so that it is heading in the new direction.
- Whilst manoeuvring in a small or confined area two carers will make the job easier.
- Move the hoist smoothly and avoid abrupt stops and turns to minimise patient swing.