

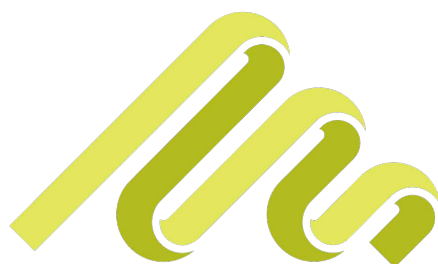

# Monarch Ceiling Hoist System

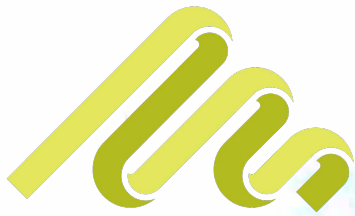

**Active Mobility**



Active Mobility



## Monarch Fixed Ceiling Hoist

The Monarch Fixed Ceiling Hoist is a complementary product to other products for individuals with mobility challenges. It is designed for use by caregivers and health care professionals to lift and transfer a person in a homecare, assisted-living or hospital environment.

The Monarch Fixed Ceiling Hoist is one of the only ceiling hoists on the market using reliable lithium ion (Li-ion) battery technology. Most competitor products use Lead-acid (heavy, toxic, low cycle life) or NiMh.

### Unique Features

- Unique Spreader Bar with Secure Sling Mechanism
- Fast - lifts up to 30% more quickly than other models
- Low lift clearance - slim profile means more room to maneuver patient
- Li-ion battery - recharges twice as fast as average competitor products
- Ultra lightweight - Weighing 8kg 35% lighter than competitors
- 200kg safe working load
- Ideal for Nursing Homes, Hospitals or Domestic Use



Fast Charging Li-ion battery



200kg



Low lift clearance



Secure Sling Mechanism



Easy-to-use controls



Magnetic Handpiece

Product Specifications Monarch Fixed Hoist

## Specifications

Model	Monarch Fixed Ceiling Hoist
Function	Patient Lifting, Room-to-Room Transfer
Total Weight	7.5 kg (Manual) 8.5kg (Motorised)
Weight Capacity	200 kg Standard
Lifts per Charge	30 to 40 cycles
Speed with 200kg	4.5 cm/s
Soft Start / Stop	Yes
Emergency Stop / Lower	Yes
Track Options	H system, Turntable, Gate, Curves, Room-to-Room, Freestanding Gantry : 2m, 3m, 4.5m, 6m, 8m
Track Compability	Compatible with all <b>Monarch</b> track and other leading track manufacturers
Application	Nursing Home, Hospital, Domestic, School, Leisure Centre, Physiotherapy

## Dimensions

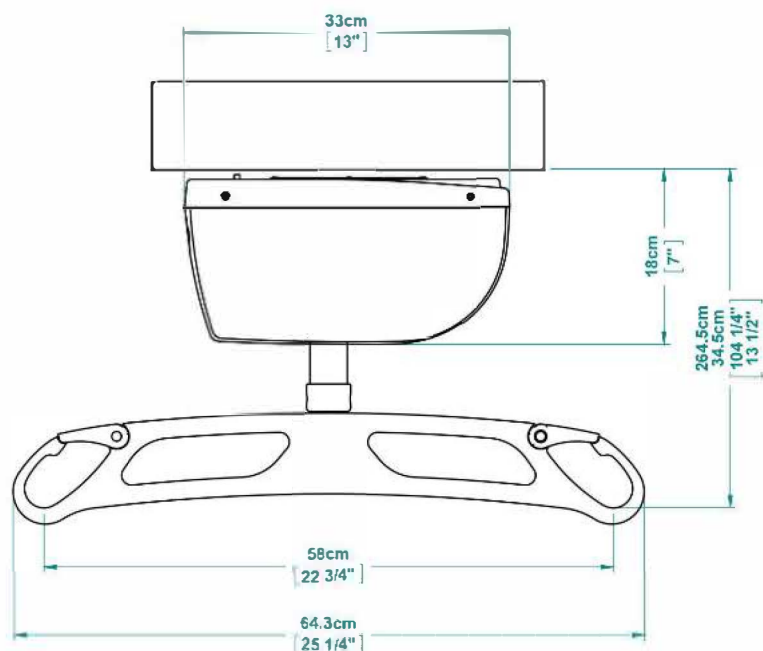
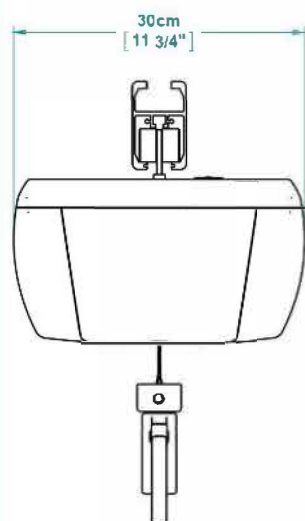



## Monarch Portable Ceiling Hoist

The Monarch Portable Ceiling Hoist is one of the lightest on the market weighing only 4.8kg, whilst lifting the industry standard of 200kg. Ideal for occasional or multiple room use, the product is robust and charges with an AC Charger. The unique spreader bar includes our industry leading Secure Sling Mechanism designed to ensure loop attachments cannot be unintentionally removed.

Perfect for rental properties, multi-room, temporary or short-term use, the Monarch Portable Ceiling Hoist can be used as a flexible alternative to fixed overhead hoists.

### Unique Features

- Ultra-lightweight, Weighing only 4.8kg
- Increased Battery Capacity
- Carry handle
- Express Recharge
- Unique Spreader Bar with Secure Sling Mechanism
- 200kg safe working load
- Ideal for transporting with the user
- Ideal for rental properties or hotels for nonpermanent use



Easy-to-use Carabiner clip



Battery is 4x more powerful



50% more lift cycles



Available with telescopic reacher



Easy Transport Handle



Unique Secure Sling Mechanism

Product Specifications Monarch Portable Hoist

# Specifications

Model Monarch Portable Ceiling Hoist

Function Patient Lifting, Room-to-Room Transfer, Temporary Use, Rental Properties

Total Weight 4.8 kg

Weight Capacity 200 kg Standard

Lifts per Charge 30 to 40 cycles

Speed with 200kg 4.5 cm/s

Travel 2300 mm

Soft Start / Stop Yes

Emergency Stop / Lower Yes

Options Standard Portable Trolley (**Monarch** track compatible), Bespoke Portable Trolley

Track Options (compatible with leading track manufacturers), Reacher.

H system, Turntable, Gate, Curves, Room-to-Room, Freestanding Gantry : 2m, 3m,

Track Compability 4.5m, 6m, 8m

Application Compatible with all **Monarch** track and other leading track manufacturers

Nursing Home, Hospital, Domestic, School, Leisure Centre, Physiotherapy

# Dimensions

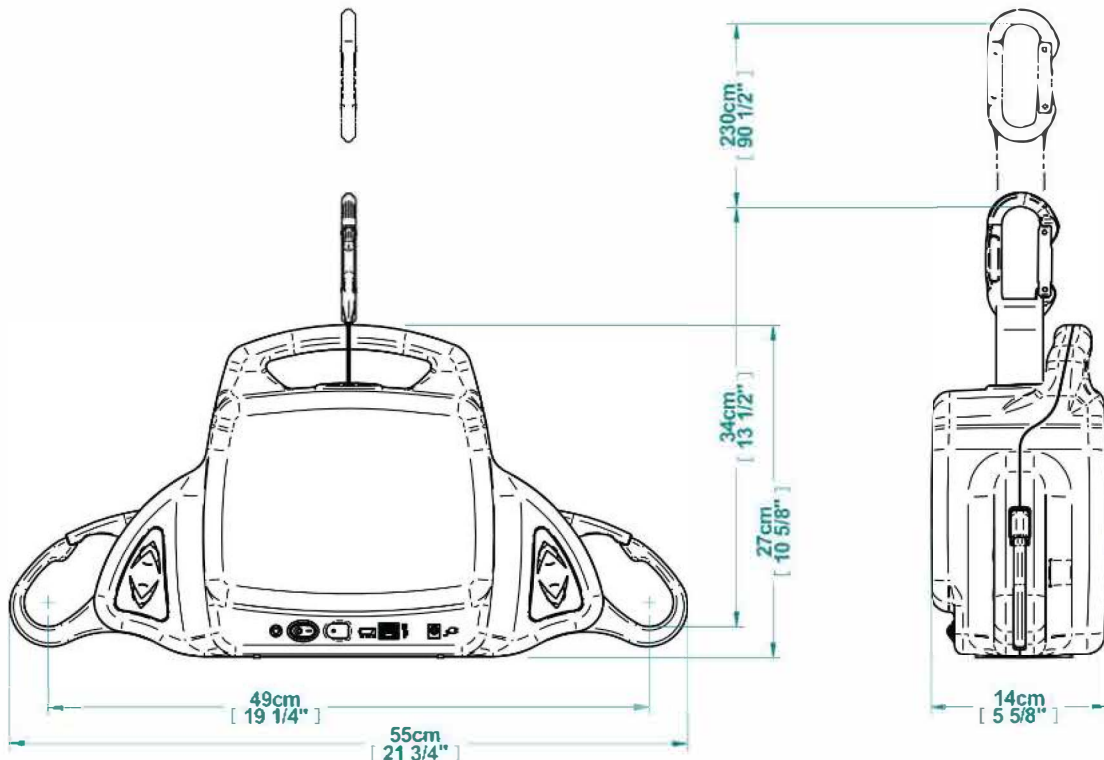

Active Mobility



Active Mobility



## Monarch Fixed Ceiling Hoist Track

The Monarch Fixed Ceiling Hoist Track offers a wide range of Ceiling Track solutions and accessories to allow installation in virtually any setting.

Options include room covering systems (also known as XY-Systems or H-Systems) that can connect up to a neighbouring room with Ceiling Hoist gate system, tight curves for small bathrooms and a flexible turntable with 16 exit possibilities.

### Unique Features

- Off-white Colour to Blend into Ceiling
- Multi-Room Gate System
- Unique No-Show Internal Bracket
- Full room covering XY (H) Systems
- Turntable Systems
- Modular Tracking Units
- Bespoke Pieces Available
- Recessed Tracking



Wall Mounted Track



90° Curve Track



Magnetic Gate System



Flush X/Y (H) System



Turntable System



Wall Post

Product Specifications Monarch Fixed Track

# Specifications

**Model** Wall Mounted or Freestanding Track

**Function** Patient Lifting, Room-to-Room Transfer, Ideal for Bathrooms, Bedrooms & Home Use

**Dimensions** 55mm x 90mm, 140mm or 180mm

**Weight Capacity** 200kg, 250kg or 400kg

**Application** Hospital, Nursing Home, School, Domestic, Swimming Pool

**Fixing Options** Wall Posts, Wall Mounted, Ceiling Mounted, Suspended Ceiling, Sloping Ceiling, Freestanding Gantry

## Configuration Options



Straight Track



45° Track



90° Track



Wall Bracket



Gate System

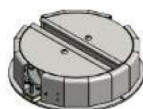

Turntable



Wall Post

## Dimensions

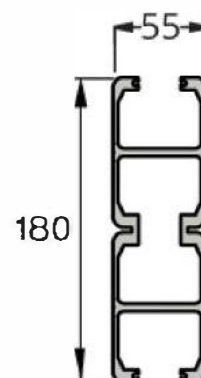
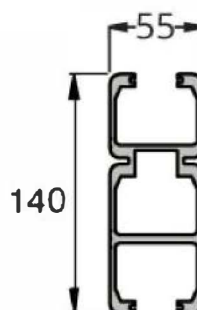
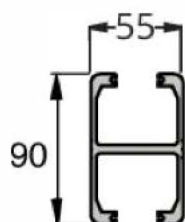
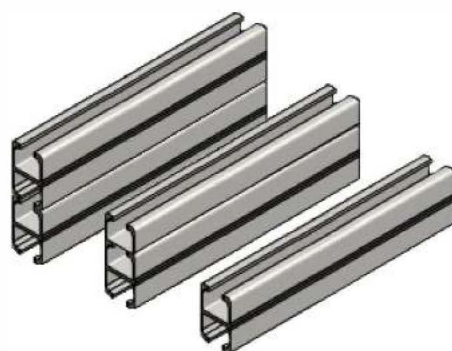



Active Mobility



## Monarch Gantry System

The Monarch Gantry System offers a temporary solution and an alternative hoisting system where installing track into the ceiling is not possible.

Ideal for use with the Monarch Portable Hoist, the Monarch Gantry has a weight capacity of up to 200kg. Unobtrusive and space saving against other Gantry systems; it has one of the thinnest base sizes available on the market which greatly reduces tripping hazard for those working around them and with an easy-to-install system, can be tailor made to the room.

### Unique Features

- Single or H system
- Monarch Fixed or Portable
- Tailor make height or length
- Low profile foot
- Made from track, cost and stock effective



Unobstructive and space saving



200kg SWL



Extremely low profile base

Product Specifications Monarch Gantry





Active Mobility

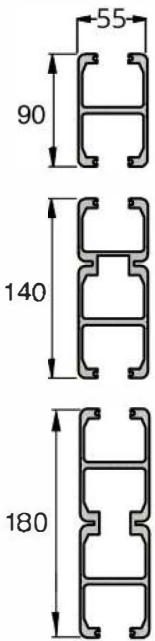

Part Number	Description
17105150 17105160 17105670	2 Meter (90mm) rail 3 Meter (90mm) rail 4 Meter (90mm) rail
17105679	4.5 Meter (140mm) rail
17105190	6 Meter (180mm) rail
17105260	45° Curve (90mm)
17105250	90° Curve (90mm)
17101770	Lateral Brace

Product Specifications Ceiling Track Elements

Part Number

Description

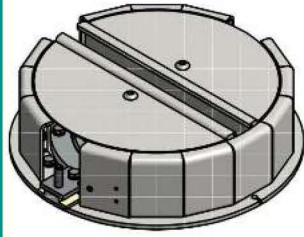

17000150

Powered Turntable

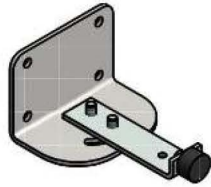

17101700

Wall Bracket

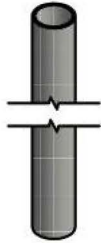

17101631

Rod Cover



1740800

Charge Sensor



17400790

Rail Joint



17102150

End Stop



17105240

End Cap



17102180

Cover Shim

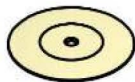

200-11140

Ceiling Plate



17400120

Quick Lock Set

# Ceiling Track Sets

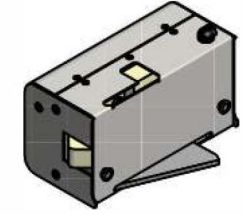

Part Number

Description

17000140

Gate System Set

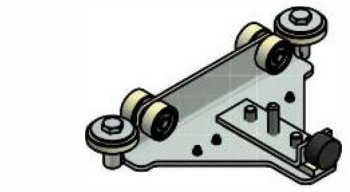
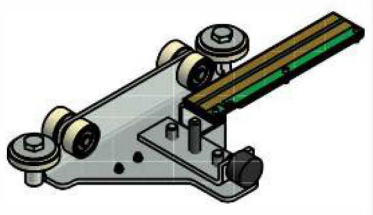

17000180

Flush XY Trolley System Set

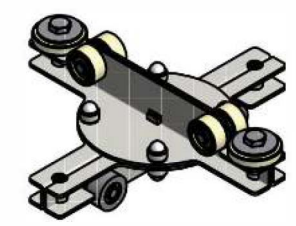
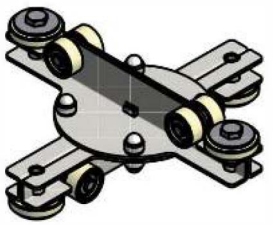

17400830

XY Trolley System Set

**Product Specifications** Ceiling Track Elements Continued...

# Ceiling Track Wall Posts



## Part Number

17106883  
17105681  
17105686

## Description

Wall Post Skirting  
Wall Post  
Wall Post Diagonal

## Dimensions

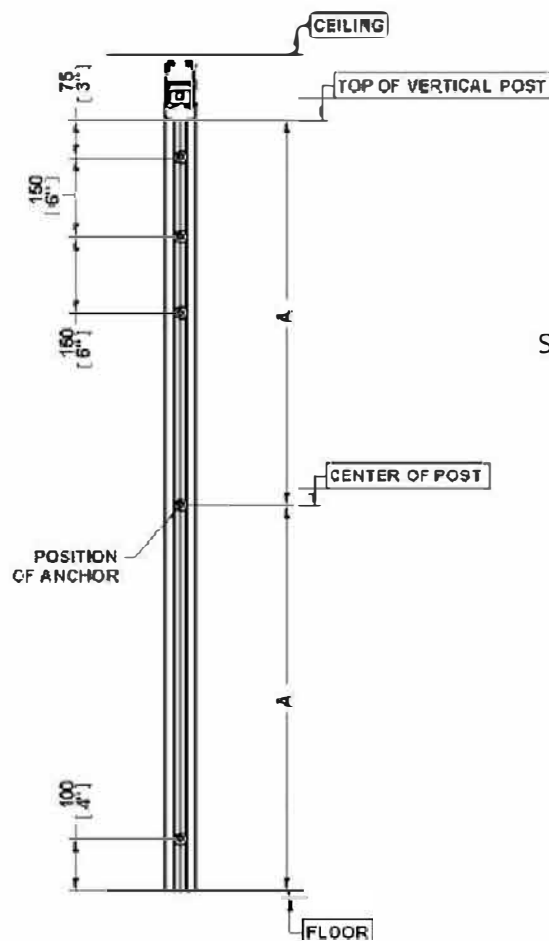

Standard Height: 2500mm  
Other Heights: Made to bespoke size  
Depth: 40mm  
Width: 60mm



Active Mobility



## Monarch Art Ceiling Hoist Decal

Bringing the fun inside with high-impact customisable designs, Monarch Art is a perfect way to help create a sensory environment, personalise a bedroom or bathroom, making patient transfer equipment fun.

Monarch Track Art has a wide scope for application, perfect for a child's bedroom or the bedroom of a patient suffering from dementia. With a range of standard designs, where Monarch Track Art really stands out, is its ability to be fully personalised.

Monarch Track can be retrospectively fit to any Monarch tracking systems.

### Unique Features

- A unique way to brighten your room
- Available in standard design or bespoke design
- Retrospective application available
- Easy application



Create A Sensory Environment



Bespoke Designs

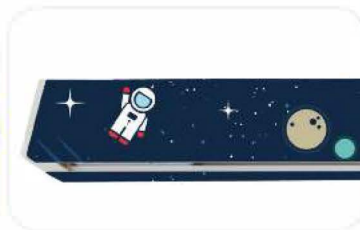

Choice of pattern or colour



Brighten Your Room



Seamless Application To Track



Retrospective Application Available

Product Specifications Monarch Track Art

# Specifications

**Model** Monarch Track Art

**Function** Bespoke Designed Decal for **Monarch Tracking System**

**Colour Options** Six Standard Designs: Space Scene, Unicorns, Birds, Clouds, Balloons or Footballs.  
Bespoke designs available upon request.

**Track Compability** Compatible with all **Monarch track**. Can be retrospectively fit.

**Application** Schools, Bedrooms, Nursing Home, Hospital, Domestic, Leisure Centre.

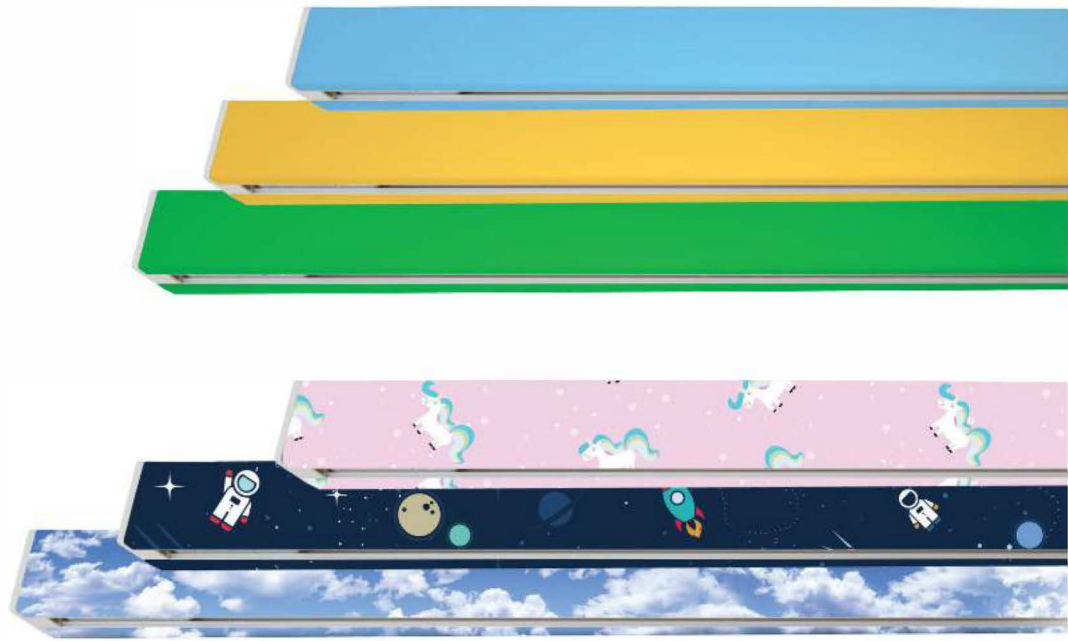

# CEILING HOIST SYSTEM

## Parts and Descriptions

### Fixings

- 1705659 Fixing into Solid Concrete with HKD Anchor
- 1705691 Chemical Resin Fixing with mesh sleeve & insert for hollow core concrete
- 1705658 L-Bracket kit and Channel with Fixing kit for TGI Joists (1 per fixing)
- 1705660 Coach Bolt with Thread-10x140mm Stud Screw

### Wall Post

- 1710568 Wall Post
- 1710569 Wall Post Diagonal
- 1710683 Wall Post Skirting

### Track

- 1710610 Rail 2m x 90mm
- 1710616 Rail 3m x 90mm
- 1710670 Rail 4m x 90mm
- 1710618 Rail 4.5m x 140mm
- 1710619 Rail 5m x 180mm

### Unistrut

- 1700684 Unistrut (Above Ceiling, Unpainted)
- 1700683 Unistrut (Below Ceiling, Painted)

### Portable Hoist

- 1700013 Monarch Portable Hoist - 130kg
- 1700014 Monarch Portable Hoist - 200kg
- 1700016 Portable Trolley
- 700-00310 Reacher
- 700-00319 Removable Hoist Trolley
- 1710519 Regent Gantry Track

### Fixed Hoist

- MS2MONFX2F2 Monarch Fixed 200kg 2FD
- MS2MONFX4F4 Monarch Fixed 200kg 4FD
- MS2MONFX2F5272 Monarch Fixed 272kg 2-F-3
- MS2MONFX4F5272 Monarch Fixed 272kg 4-F-3

### Instride Trolley Set

- 1700016 Instride Trolley Set

### Quick Lock Set

- 1700020 Quick Lock Set

### Spreader Bars

- 3200030 X-Shaped Spreader Bar
- 3200020 Manual Cradle
- 3210660 Spreader Quick Release

### Ceiling Plate

- 171091601 Ceiling Plate

### Wall Bracket

- 17101001 Wall Bracket

### Charger

- 1700090 Charger

### Charging Sensor

- 17400900 Charging Sensor

### Infra-red Kit

- 17000132 Infra-red Kit

### XY Trolley Charger Interface

- 17401820 XY Trolley Charger Interface

### XY Trolley System Set

- 171000301 XY Trolley System Set

### Cable System

- 17000140 Cable System

### Lanka Base

- 1710770 Lanka Base

### Visible Base

- 70011350 Visible Base

### Powered Turntable

- 17000150 Powered Turntable

### Joint Clamp

- 171021601 Joint Clamp

### Spring Pin

- 17102010 Spring Pin

### 45° Curve

- 17105260 45° Curve

### 90° Curve

- 17105250 90° Curve

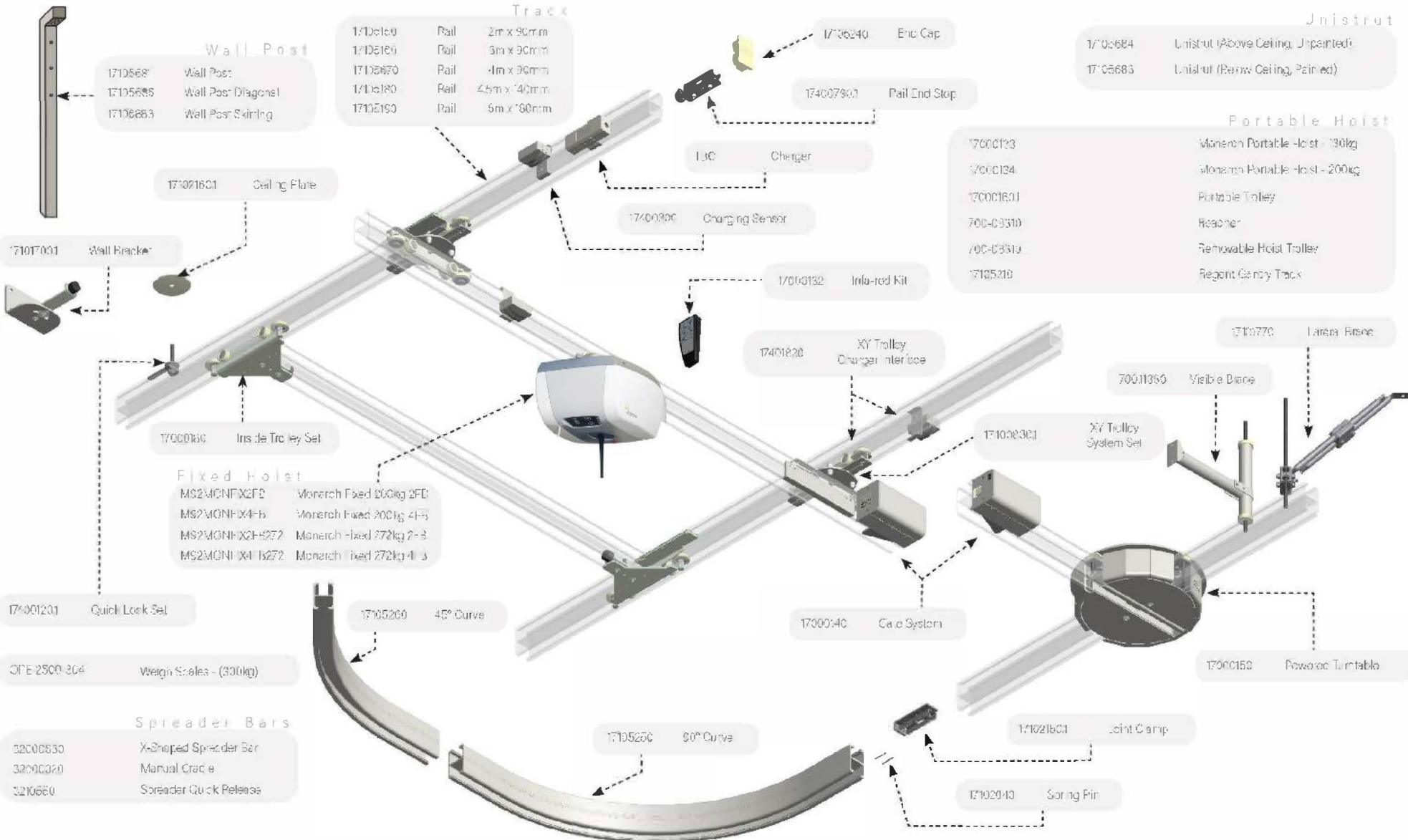

# MONARCH GANTRY SYSTEM

## Parts and Descriptions

Track

17105150	Rail	2m x 90mm
17105160	Rail	3m x 90mm
17105180	Rail	4.5m x 140mm
17105190	Rail	6m x 180mm



17000160.1 Portable Trolley



- 17000133 Monarch Portable Hoist 130kg
- 17000134 Monarch Portable Hoist 200kg
- 700-08310 Reacher

