

ARES 155

# Allegro LITE



A new generation light weight aluminium lifter evolved from the needs of the carer.

**Allegro**  
CONCEPTS PTY LTD

# Allegro LITE



## PRODUCT DESCRIPTION

Aluminium lift Ares 7101.

- Aluminium lift with a Safe Working Load (SWL) of 155kg
- Linak powered lifting function
- Foot pedal control for base width adjustment
- Strong and comfortable handles for easy manoeuvring
- Equipped with 75mm front castors and 100mm lockable rear castors
- Jumbo Care diagnostic control and service monitor system
- Easy access emergency stop button
- Electric and manual emergency lowering devices
- Anti-entrapment feature – lowering of boom stops on resistance



Rear castors with brakes for security



Simple adjustment of base width with foot pedal



Quick release mast



Extra low 34cm lifting height to allow floor lifts

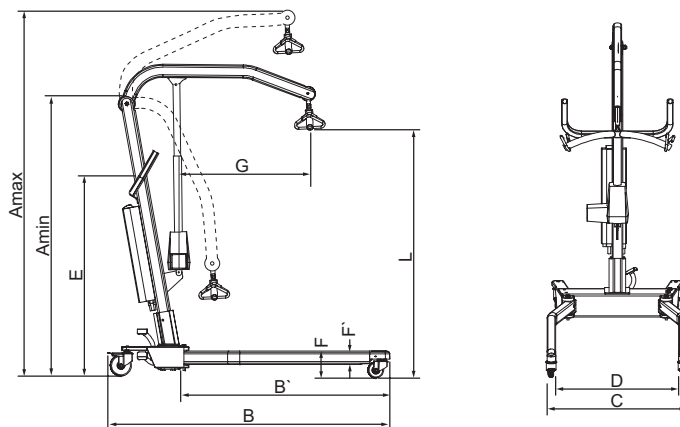

ITEM NO	MAX LOAD	L		A		B	B1	C	D	E	F	F1	G	NW	Turning Radius
		MAX	MIN	MAX	MIN										
7101	155	165.5	40.5	176.5	138	127	96.5	68~98	60~90	110	13.5	7.5	88	31kg	128

\* All measurements are shown in centimetres.

### Allegro Concepts Pty Ltd

30-32 James Street Lidcombe NSW 2141  
 Phone: (02) 9749 7812 Fax (02) 9749 2144  
 Email: sales@allegroconcepts.com.au

